

Precise Tenons by Machine

Fit tenons fast using the tablesaw and bandsaw

BY TIM COLEMAN

3 SIMPLE STEPS



1. DEFINE THE SHOULDERS



2. CUT THE CHEEKS



3. TRIM TO WIDTH

When I cut mortise-and-tenons, I look at the job as a production process. Seldom is there just one tenon in a piece of furniture, so it is imperative that I have a way to ensure consistent, repeatable results.

Toward that end, I developed a system for cutting tenons on the tablesaw that allows me to move through the process quickly and efficiently. All the setup and fitting is done with test pieces. Once I get the setup dialed in, I can crank out the tenons in bunches, and all of them will fit right off the saw, with very little fine-tuning by hand.

Make extra stock for test pieces

The process begins with a full-size layout on paper. I draw several views showing the joinery in plan and elevation. With the drawing in hand, I mill all stock to dimension, including plenty of extra for test pieces to set up all the cuts. Accurate tenons begin with accurate milling. Consistent thickness is especially critical, and I wait to do any hand-surfacing until all the joinery is done. I cut all the mortised parts to length, but I treat the tenoned parts differently.

If the tenon length varies, I cut the parts so that all the tenons can be machined to the same length at first, with the shorter ones cut to final length later. This takes a little planning to make sure the shoulders end up in the right place, but it saves me from having to adjust the blade height for different tenon lengths. Make sure the ends are square across in thickness and width. If needed, adjust the blade tilt and crosscut device to correct them.

Cut the mortises first

I cut mortises first, typically with a hollow-chisel mortiser. While I'm cutting the mortises in the real stock, I also cut two extra mortises in test stock. I cut two because repeated test fittings in the same sample mortise will begin to enlarge it and give an inaccurate fit. Once all the mortises are done, you can start on the tenons. By the way, I cut the joinery before I do any shaping of the parts.

Tenons next, starting with the shoulders

Because I cut the tenons all to the same length, I have to do the layout only on a couple of test pieces. That said, I do scribe the shoulders on all the parts, which reduces tearout from the tablesaw cuts.

Cut the shoulders first. I use a combination blade and a miter gauge. Because this is a non-through cut, I can use the tablesaw's fence as a stop so that the shoulders are all cut in the same spot. I use a test piece to set the fence and the blade height. I cut the shoulders at the base of the cheeks first, setting the blade height so that it's just shy of the cheek, about $\frac{1}{32}$ in. This little bit of material gets chiseled away later. I typically center the tenon on the rail or apron for efficiency. This way I can make both shoulder cuts simply by flipping the workpiece. The exception is when the rail or apron is curved in front. In those cases, the tenon must be offset, so you'll need to dial in two setups at the tablesaw.

Next I cut the top and bottom shoulders, again keeping the blade about $\frac{1}{32}$ in. from the tenon. The top shoulder may be

SHOULDERS ARE THE STARTING POINT



Set the blade height just below the final tenon thickness.

Shoulders first. With the workpiece facedown, raise the blade to within about $\frac{1}{32}$ in. of the tenon cheek. Use the tablesaw fence as a stop, holding the workpiece against the miter-gauge fence and squarely against the tablesaw fence.



Top and bottom, too. To cut the top and bottom shoulders, keep the fence in the same position. Adjust the blade so it's about $\frac{1}{32}$ in. from the base of the tenon.



Close shave. Zip off most of the waste using the bandsaw. Be sure to use a fence, and aim to leave the tenon about $\frac{1}{16}$ in. over final thickness.

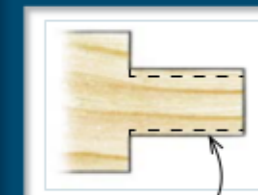

Trim slightly wider than final tenon thickness.

SIMPLE JIG TRIMS THE CHEEKS



The key to perfect cuts. Coleman uses a shopmade tenoning jig (above) to cut the cheeks. The jig rides a tall auxiliary fence that he screws to his tablesaw fence. He sets up the cuts using a test piece. His goal is to trim each tenon with just two cuts, one on each cheek.

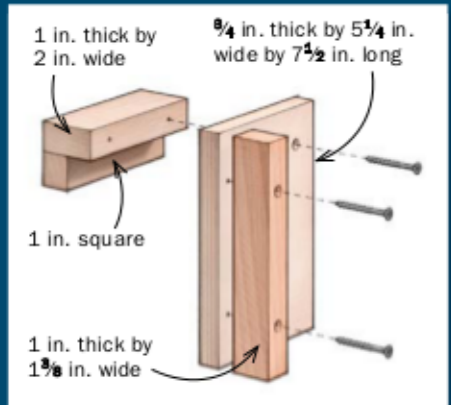

deeper than the bottom and require a change in the depth of cut. For efficiency and consistency, make all the cuts with one setup before moving on to the next: That means cut the top shoulders in all the parts, then the bottom shoulders, or vice versa.

Cut the cheeks in two steps

After the shoulders are done, it's on to the cheeks. I rough-cut the cheeks on the bandsaw, leaving the tenons about $\frac{1}{16}$ in. too thick, and then I finish them at the tablesaw using a shopmade tenoning jig with a tall auxiliary fence. The bandsaw step is tempting to avoid, but I have found that I achieve more accurate and consistent tenons at the tablesaw when the blade is just skimming the cheek face. There is less heat buildup and less blade deflection.

For the tablesaw cuts, I use a flat-top rip blade (Amana heavy-duty ripping blade, 20 tpi), which allows me to get very close to the shoulder with minimal cleanup at the base of the tenon.

For a tenon centered in the thickness of the workpiece, there is only one fence setup, with the piece being flipped around to cut both cheeks. I position the fence so the blade will cut on the

TIP CHECK THE FIT

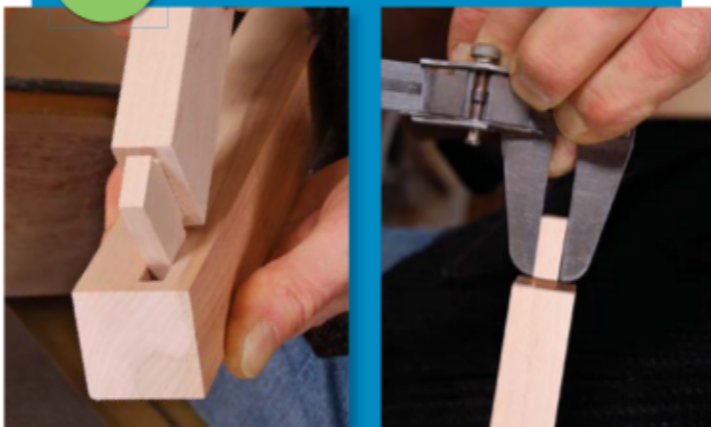

No tapers allowed. Even if you've squared the blade to the saw table, the tall tenon cuts could be off and could taper from one end to the other. The probable cause is the auxiliary fence being a pinch off 90°. Check the test tenon with calipers, and look for any change in thickness.

THE FINAL TOUCHES



Back to the bandsaw. Cut the tenons to final width on the bandsaw. Set up the bandsaw fence using the test piece, then bang out all of the tenons at the same time.

outside of the cheek. To set up the cuts, I use a test piece, with the blade raised just above the table ($\frac{3}{32}$ in.). Make cuts for both cheeks and test the fit in the sample mortise. When you're satisfied with the fit, raise the blade to within $\frac{1}{64}$ in. of the tenon shoulder, and cut along the full length of the test tenon.

There's one more check before you cut the real tenons. You want to make sure that the tenon's thickness is even from top to bottom so there's a solid glue bond with the mortise walls. Even though the blade may be perfectly square to the table, the resulting cut is what is most important. Use a caliper to check, and adjust blade tilt to compensate.

Now you can cut all the tenon cheeks on the actual pieces. Periodically check the fit during the process to make sure that nothing has changed. Once the tenon cheeks are cut, I trim the tenons to the correct width. I usually do this on the bandsaw. Then I cut them to length on the tablesaw.

Only light cleanup required

With my method, there's very little work at the bench. I use the corner of a chisel to clear away the waste at the base of the tenon. While I'm there I give a slight undercut around the base, a small extra step that ensures that the tenon shoulders are tight against the mortise face. I also soften the leading edges of the tenon with a file. This allows easier entry into the mortise.

Finally, I label all tenoned pieces as I fit them to their corresponding mortises. With my tenoning method I don't have to do much test-fitting, a bonus since too much of it can bumish the surfaces of the tenons and mortises. Bumished surfaces are not good glue surfaces.

Done. Have some lunch. □

Tim Coleman is a renowned furniture maker and designer in Shelburne, Mass.



A little off the bottom and top. Use a chisel to trim the small amount of waste at the base of the tenon left by the combination blade (top). Coleman likes to go a bit deeper, undercutting that area to ensure a snug fit. He also relieves the corners on the end of each tenon with a file (bottom).



The end is here. Test-fit each tenon in its mortise, and mark the parts so you don't lose track. You're now ready for assembly.

